

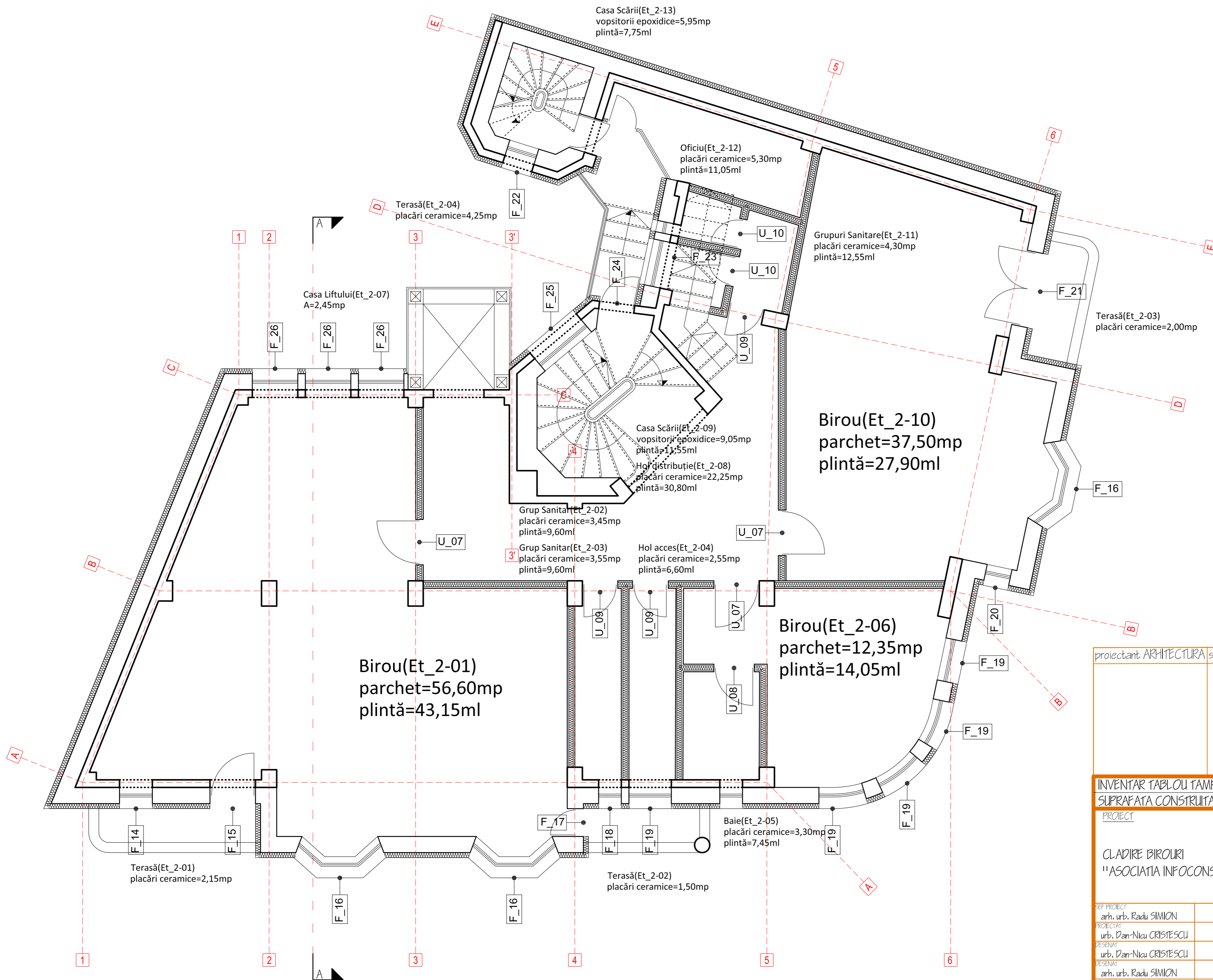

proiectant ARHITECTURA	stampila ARHITECT	proiectant PSI	stampila VERIFICATOR

INVENTAR TABLOU TAMPLARIE CLADIRE ASOCIATIA INFOCONS - ETAJ I			
SUPRAFATA CONSTRUITA 187,45mp			
PROIECT	PROIECTANT GENERAL	 InfoCons <small>protectia-consumatorilor.ro</small>	PROIECT
CLADIRE BIROURI "ASOCIATIA INFOCONS"	HUZUR STUDIO		NR.H-A-0216
DEF. PROIECT arh. urb. Radu SIMION	BENEFICIAR ASOCIATIA INFOCONS		FAZA PROPLINERE ARH. (D.T.A.C.)
PROIECTAT urb. Dan-Nicu CRISTESCU	IDENTIFICARE IMOBIL		DATA 01.09.2016
PREZENTAT urb. Dan-Nicu CRISTESCU	str. VIITORULUI nr.133, BUCURESTI 5.2		SCARA 1:50
VERIFICAT arh. urb. Radu SIMION	TITLUL PLANSEI		NR.PLANSA
	PLAN TABLOU TAMPLARII ETAJ I (P.Th.)		TITLUL PLANSEI
			TTET-I-00



proiectant ARHITECTURA	stampila ARHITECT	proiectant PSI	stampila VERIFICATOR

INVENTAR TABLOU TAMPLARIE CLADIRE ASOCIATIA INFOCONS - ETAJ 2			
SUPRAFATA CONSTRUITA 187,45mp			
PROIECT	PROIECTANT GENERAL	 InfoCons <small>protectia-consumatorilor.ro</small>	PROIECT
CLADIRE BIROURI "ASOCIATIA INFOCONS"	HUZUR STUDIO		NR./H-A-0216
DEF. PROIECT	arh. urb. Radu SIMION	BENEFICIAR ASOCIATIA INFOCONS	FAZA
PROIECTAT	urb. Dan-Nicu CRISTESCU		PROPOUNERE ARH. (D.T.A.C.)
PREZENTAT	urb. Dan-Nicu CRISTESCU	str. VIITORULUI nr.133, BUCURESTI 5.2	DATA
VERIFICAT	arh. urb. Radu SIMION		01.09.2016
			SCARA
			1:50
			NR. PLANSA
			TITLUL PLANSEI
			PLAN TABLOU TAMPLARIE ETAJ 2 (P.Th.)
			TITLUL PLANSEI
			TITLUL PLANSEI

U_07



TABLOU TÂMPĂRIE UȘI

InfoCons
protectia-consumatorilor.ro

str. VIITORULUI 133
S.2 BUCUREȘTI

DESCRIERE:

CARACTERISTICI TEHNICE :

FOAIE DE USA DIN STICLA, CU DOUA SAU TREI
BALAMALE
USA INTERIOR

MATERIALE ȘI ACCESORII :

STICLA SECURIZATA
FARA TOC SAU TOC METALIC
BALAMALE ALAMA
MANER, SILD, ROZETA ALAMA

AMPLASARE CORP LOCATIE

NUMAR BUCATI

ALCATUIRE PERETE

FINISAJ

U_07

4-DESIDERE DREAPTA
2-DESIDERE STANGA

GHIPS-CARTON

VOPSEA LAVABILA

ELEVATIE TAMPLARIE

SCARA 1:40

ELEVATIE GOL

SCARA 1:40

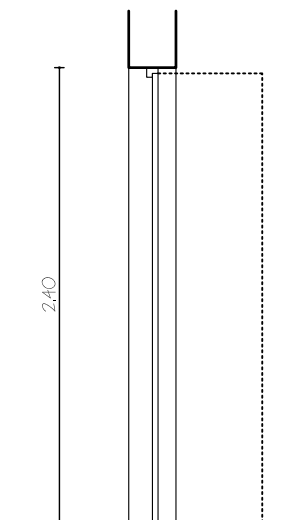
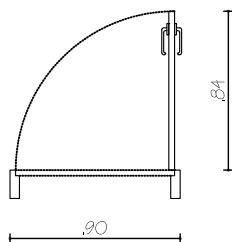
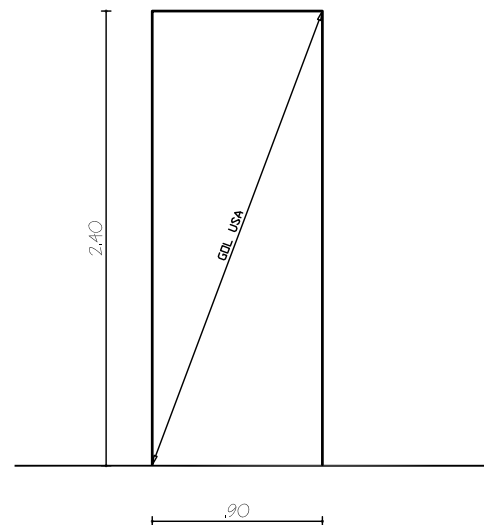
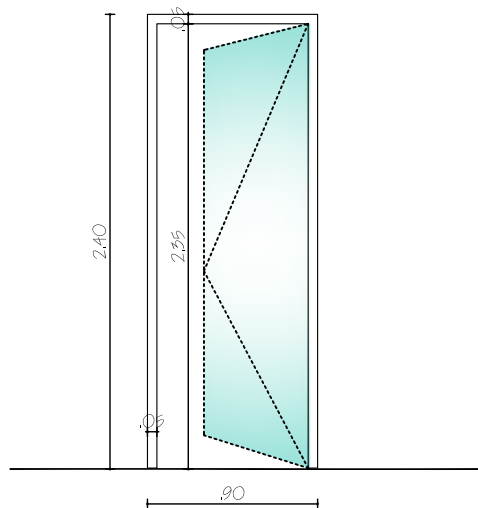

PLAN

SCARA 1:40

SECTIUNE

SCARA 1:40

REVIZII DATA

REV. NR. : 000

OBSERVATII :

001

USA DE INTERIOR

002

003

004

SEF PROIECT

arh. urb. Radu SIMION

FAZA :

D.D.E.

PROIECT NR : H_A_0216

PROIECTAT

arh. urb. Radu SIMION

DATA :

10.08.2016

REVIZIA : 000

DESENAT

arh. Dan-Nicu CRISTESCU

DESENAT

arh. urb. Radu SIMION

VERIFICAT

arh. Sandu STIURCA

U_08



TABLOU TÂMPLĂRIE UȘI

InfoCons
protectia-consumatorilor.ro

str. VIITORULUI 133
S.2 BUCURESTI

DESCRIERE:

CARACTERISTICI TEHNICE :

FOAIE DE USA DIN MDF FURNIRUIT, CU TREI SAU PATRU BALAMALE
USA INTERIOR

MATERIALE ȘI ACCESORII :

MDF FURNIRUIT
TDC MDF FURNIRUIT
BALAMALE ALAMA
MANER, SILD, ROZETA ALAMA

AMPLASARE CORP LOCATIE

NUMAR BUCATI

ALCATUIRE PERETE

FINISAJ

U_08

3-DESIDERE STANGA

GIPS CARTON

VOPSEA LAVABILA

ELEVATIE TAMPLARIE

SCARA 1:40

ELEVATIE GOL

SCARA 1:40

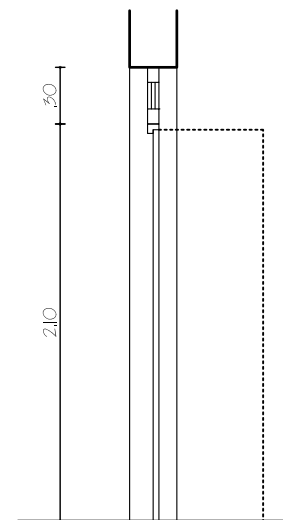
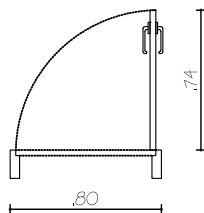
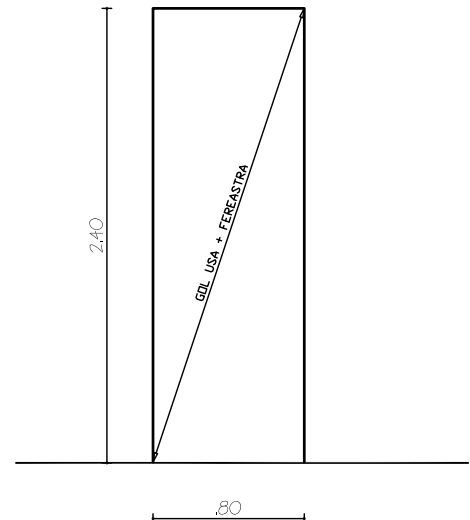
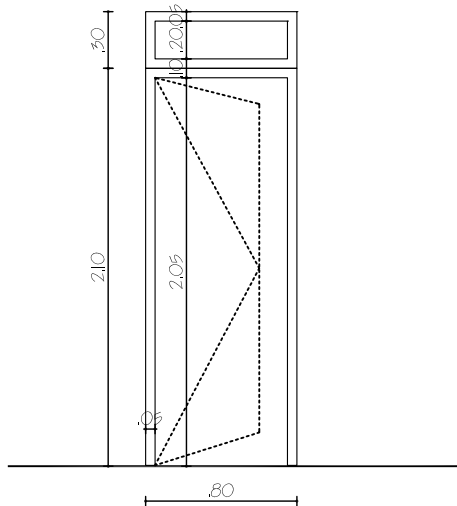

PLAN

SCARA 1:40

SECTIUNE

SCARA 1:40

REVIZII DATA

REV. NR. : 000

OBSERVATII :

001

USA DE INTERIOR

002

003

004

SEF PROIECT

arh. urb. Radu SIMION

FAZA :

D.D.E.

PROIECT NR : H_A_0216

PROIECTAT

arh. urb. Radu SIMION

DATA :

10.08.2016

REVIZIA : 000

DESENAT

arh. Dan-Nicu CRISTESCU

DESENAT

arh. urb. Radu SIMION

VERIFICAT

arh. Sandu STIURCA

U_09

TABLOU TÂMPLĂRIE UȘI

DESCRIERE:

CARACTERISTICI TEHNICE :

 FOAIE DE USA DIN MDF FURNIRUIT, CU TREI SAU
 PATRU BALAMALE
 USA INTERIOR

MATERIALE ȘI ACCESORII :

 MDF FURNIRUIT
 TDC MDF FURNIRUIT
 BALAMALE ALAMA
 MANER, SILD, ROZETA ALAMA

AMPLASARE CORP LOCATIE

U_09

NUMAR BUCATI

 3-DESIDERE STANGA
 4-DESIDERE DREAPTA

ALCATUIRE PERETE

GIPS CARTON

FINISAJ

VOPSEA LAVABILA

ELEVATIE TAMPLARIE

SCARA 1:40

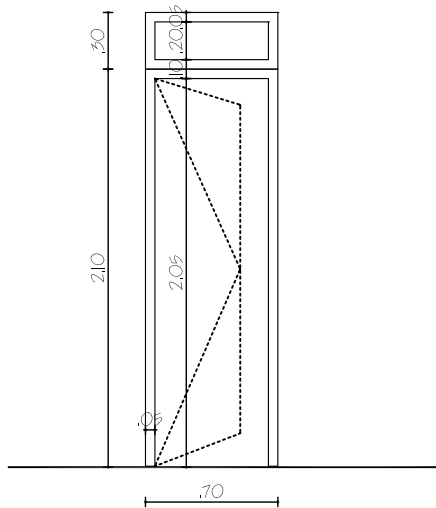

ELEVATIE GOL

SCARA 1:40

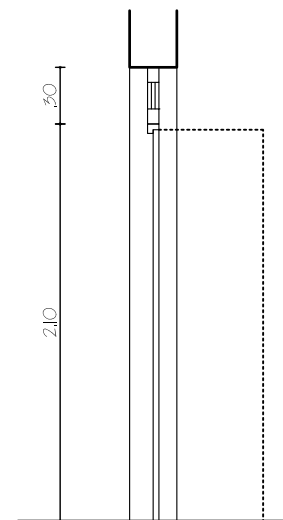
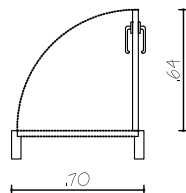
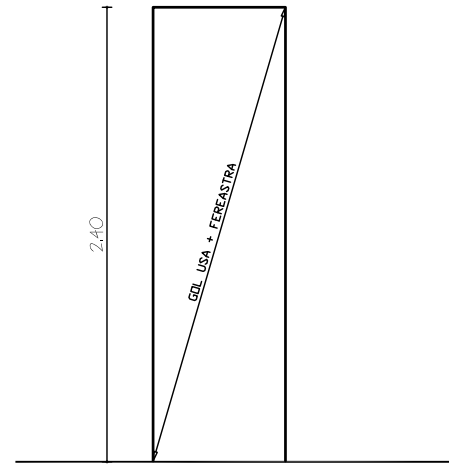

PLAN

SCARA 1:40

REVIZII	DATA
001	
002	
003	
004	

REV. NR. : 000

SECTIUNE

SCARA 1:40

OBSERVATII :

USA DE INTERIOR

SEF PROIECT	arh. urb. Radu SIMION
PROIECTAT	arh. urb. Radu SIMION
DESENAT	arh. Dan-Nicu CRISTESCU
DESENAT	arh. urb. Radu SIMION
VERIFICAT	arh. Sandu STIURCA

FAZA : D.D.E.

PROIECT NR : H_A_0216

DATA : 10.08.2016

REVIZIA : 000

U_10



ASOCIATIA INFOCONS

TABLOU TÂMPLĂRIE UȘI

InfoCons
 protectia-consumatorilor.ro

str.VIITORULUI 133
 S.2 BUCURESTI

DESCRIERE:

CARACTERISTICI TEHNICE :

FOAIE DE USA DIN MDF FURNIRUIT, CU TREI SAU PATRU BALAMALE
 USA INTERIOR

MATERIALE ȘI ACCESORII :

MDF FURNIRUIT
 TDC MDF FURNIRUIT
 BALAMALE ALAMA
 MANER, SILD, ROZETA ALAMA

AMPLASARE CORP LOCATIE	NUMAR BUCATI	ALCATUIRE PERETE	FINISAJ
U_10	1-DECHIDERE STANGA 1-DECHIDERE DREAPTA	GIPS CARTON	VOPSEA LAVABILA

ELEVATIE TAMPLARIE	SCARA 1:40	ELEVATIE GOL	SCARA 1:40

--	--

PLAN	SCARA 1:40	SECTIUNE	SCARA 1:40
REVIZII	DATA	REV. NR. : 000	OBSERVATII :
001			USA DE INTERIOR
002			
003			
004			
SEF PROIECT	arh. urb. Radu SIMION	FAZA :	PROIECT NR : H_A_0216
PROIECTAT	arh. urb. Radu SIMION	D.D.E.	REVIZIA : 000
DESENAT	arh. Dan-Nicu CRISTESCU	DATA :	
DESENAT	arh. urb. Radu SIMION	10.08.2016	
VERIFICAT	arh. Sandu STIURCA		